

CIRCUIT:007

位置 POSITION	电路 CIRCUIT
1(INITIAL)起始	OFF
2	C+1

线路图
CIRCUIT DIAGRAM

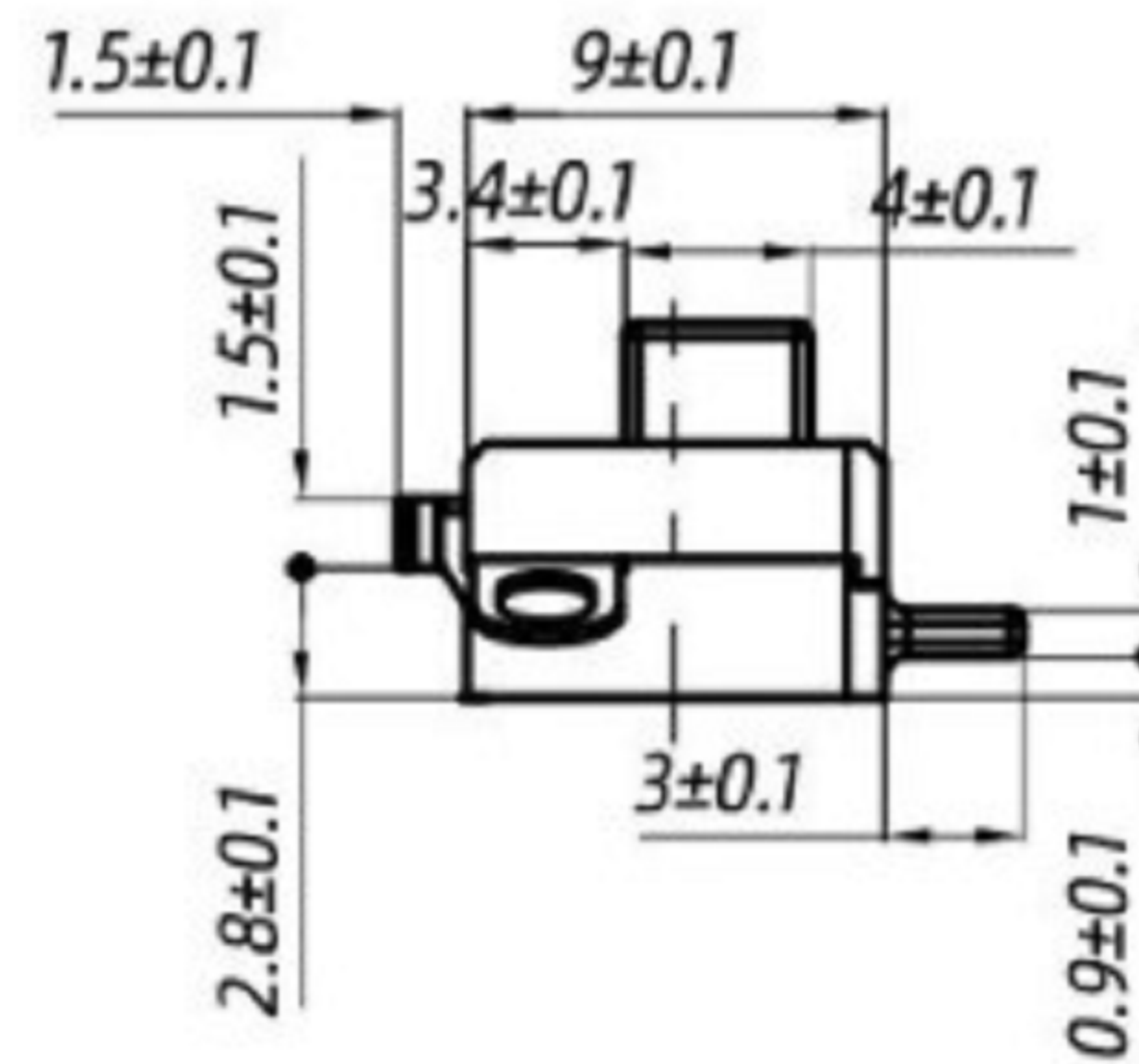
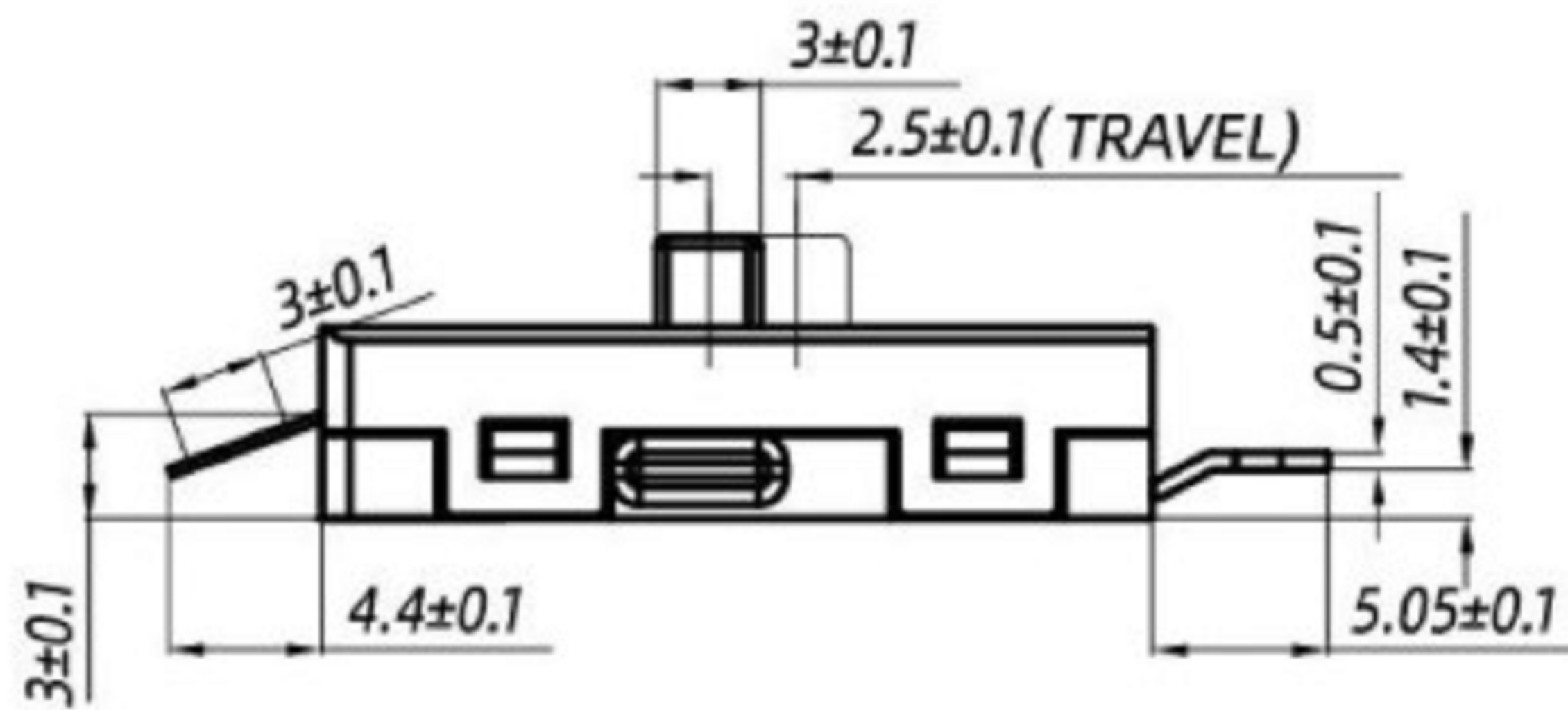
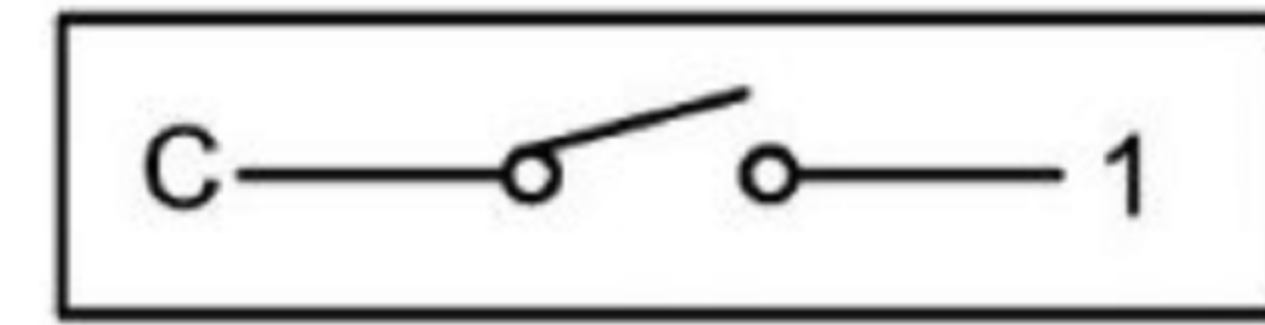

两档滑动开关

- 滑动开关型号 SLIDE SWITCH MODEL: KND-1-AS007
- 焊线端子 SOLDER CONNECTOR TYPE;
单刀双掷 . 多回路 SINGLE POLE DOUBLE THROW;
- 额定值 RATING: 16(4)A 125/250VAC μ T105
10(2)A 125/250VAC μ T85
7(2)A 125/250VAC μ T85
5(1)A 125/250VAC μ T85
- 接触电阻 CONTACT RESISTANCE: <50m Ω (INITIAL)
- 绝缘电阻 INSULATION RESISTANCE: \geq 100M Ω (DC500V/1MIN)
- 介电强度 DIELECTRIC STRENGTH: 1500V /5mA /1MIN
- 机械寿命 MECHANICAL LIFE: >100000 CYCLES
- 电气寿命 ELECTRICAL LIFE: >50000 CYCLES
- 端子手工焊接条件 SOLDER ABILITY OF TERMINAL: MAX260°C. 3S
- 操作力 OPERATION FORCE: 350 \pm 150gf
- 所有部件均使用环保材料 ALL MATERIALS ARE RoHS COMPLIANT

NO.	PARTS	MATERIALS	QTY	FINISH
5	CONTACT CLIP	PBS STRIP	1	Ag PLATED
4	TERMINAL	BRASS	3	Ag PLATED
3	BASE	PHENOLIC RESIN	1	NATURAL
2	FRAME	STEEL STRIP	1	Ni PLATED
1	KNOB	POM	1	BLACK

东莞市高迪电子有限公司
DONG GUAN GAO DI ELECTRONICS CO., LTD

TOLERANCE UNLESS OTHERWISE STATED:
Up to 5 \pm 0.2
Above 5 ~ 15 \pm 0.3
Above 15 ~ 30 \pm 0.4
Above 30 ~ 50 \pm 0.5
Angle \pm 0.3°

3RD. ANGEL'S

UNITS MM

DRAWN BY: Ming Ming Zou	DATE 11/19/14	MAT'L	TITLE SWITCH
CHECKED BY: Ning Ning Su	DATE 11/19/14	FINISH	MODLE SLIDE SWITCH
APPROVED BY: Jia Xiang	DATE 11/19/14	SCALE 1:1	DWG NO. GD-KND-1-AS007
SHEET NO. 1 of 1		PART NO.	SIZE A4 VER R2

ITEM NO.	DESCRIPTION	DRAWN	DATE
2	新增SPEC	Jack	111914
1	新增尺寸	Jack	061614